

STANDARD RECIPROCATING PLACER

Multiple Applications
PLC Controlled

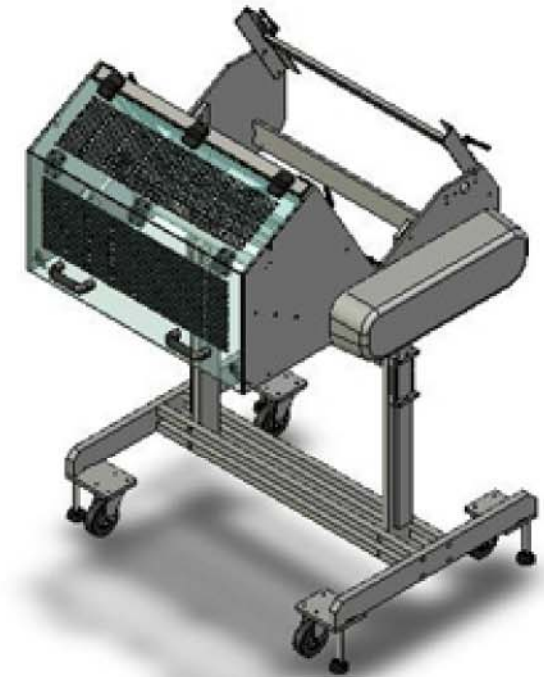

Flexible

Versatile

Dependable



GRAPHIC PACKAGING
INTERNATIONAL, INC.
MINNESOTA AUTOMATION PRODUCTS

Flexibility is the key to the design of the Standard Reciprocating Placer. Use as a stand-alone machine or integrate into your existing system. Graphic Packaging has successfully interfaced this Reciprocating Placer with many major brands of equipment.

Used for multiple applications or as a dedicated product-feeding device, the Standard Reciprocating Placer is a low maintenance machine that will withstand the rigors of manufacturing.

Options such as the Quick-Change magazine are perfect for lean manufacturing. Less down time for re-tooling means more production time and higher outputs.

Everyday you make every effort to gain extra performance in your production lines. Minnesota Automation Products from Graphic Packaging are quality products with unmatched customer support.

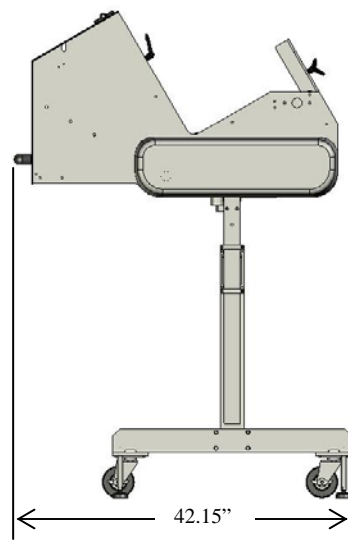
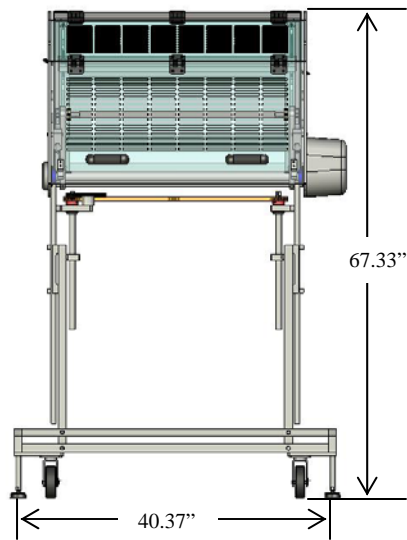

Key Features

- **PLC Controlled**
PLC brand flexibility allows us to configure this machine to your requirements.
- **Speeds**
Maximum speeds of 60 pieces per minute
- **Quick Changeovers**
Many of our machines are for multiple product configurations. Using optional Quick-Change Magazines enables the end user to maximize production.
- **Maintenance**
This machine has a minimal number of moving parts. Fewer moving parts equal less maintenance.
- **Power / Air Requirements 120VAC and 80 PSI**
Flexibility is the key. Roll the machine up to many conveyor configurations, plug it in and you are ready.

Options

- **Construction Grade**
Grade #1 Standard Finish – Normal applications where machine is not subject to wash down.
Grade #2 Standard Stainless Finish – Applications where machine is subject to occasional wash down.
Grade #3 Wash Down Finish – Designed for applications where machine is subject to high pressure, high temperature, and caustic wash down.
- Multiple Product Lanes
- Non Vacuum Pin-Style Grippers
- Glue Applications
- Portable Stand with Rapid Height Adjustment
- Casters for Mobility
- Horizontal Powered Magazines
- Quick Change Magazines
- Shuttling Magazines
- Back to Back Air Cylinders
- Bar Code Reader and Verification
- Cycle Counter
- Line Controls to meet your requirements

Products

Coupons – Credit Cards – Back Cards – Phone Cards – Labels Trays – Lids – Bowls – Tubs – Clamshell Trays – Paper – Plastic Premiums – Envelopes – Pouches – Hang Tags – Inserts – CD's - Pizza Circles – Warranty Cards – Promotional Literature – Pads – Glass - **Many, many more**



GRAPHIC PACKAGING

INTERNATIONAL, INC.
MINNESOTA AUTOMATION PRODUCTS

975 3rd Street SW • PO Box 190 • Crosby, MN 56441

1.888.800.6861 • 218.546.2222 • Fax 218.546.2252

www.minnesotaautomation.com • E-mail: ma@graphicpkg.com

Maximum Product Sizes for Arm Length

Arm Length	Prod Height	Width 12" Model	Width 24" Model	Width 36" Model	Width 48" Model
9" Arm	15"	14-1/2"	26-1/2"	38-1/2"	50-1/2"
12" Arm	21-1/2"	14-1/2"	26-1/2"	38-1/2"	50-1/2"
15" Arm	27-3/4"	14-1/2"	26-1/2"	38-1/2"	50-1/2"