

# SECONDARY MOTION ROTARY

AC Inverter Drive

AC Servo Motor Drive

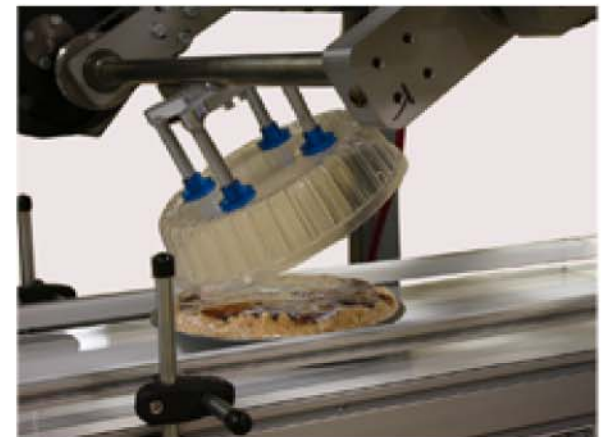

**Flexible**

**Versatile**

**Dependable**



**GRAPHIC PACKAGING**  
INTERNATIONAL, INC.  
MINNESOTA AUTOMATION PRODUCTS

Flexibility was the key in the design of the Secondary Motion Rotary. A need existed for a high-speed accurate rotary placer to handle deep bowls and lids. The Secondary Motion rotary fills that need.

Use as a stand-alone machine or integrate into your existing system. Graphic Packaging has successfully interfaced this Rotary Placer with many major brands of equipment.

Used for multiple applications or as a dedicated product-feeding device, the Secondary Motion Rotary Placer is a low maintenance machine that will withstand the rigors of manufacturing.

Options such as the Quick-Change magazine are perfect for lean manufacturing. Less down time for re-tooling means more production time and higher outputs.

Everyday you make every effort to gain extra performance in your production lines. Minnesota Automation Products from Graphic Packaging are quality products with unmatched customer support.

### Key Features

- Control Options
- Ability to pick deep lids / containers  
Machine designed with the motion required to remove deep trays and lids from the magazine.
- Continuous Motion  
Increased production and reduce labor
- Quick Changeovers  
Many of our machines are for multiple product configurations. Using optional Quick-Change Magazines enables the end user to maximize production.
- Product contact reduced  
Human contact minimized
- Single stream of product  
Place this machine above your conveyor.
- Speeds up to 120 placements per minute

### Options

- Construction Grade  
Grade #1 Standard Finish – Normal applications where machine is not subject to wash down.  
Grade #2 Standard Stainless Finish – Applications where machine is subject to occasional wash down.
- 120° - 240° placement rotation or both
- Servo Controlled (Random Placement)
- Touch Screen Operator Interface
- Apply labels, printing, or coding
- Glue Applications
- Portable Stand with Rapid Height Adjustment
- Casters for Mobility
- Horizontal Powered Magazines
- Quick Change Magazines
- Shuttling Magazines
- Bar Code Reader and Verification
- Cycle Counter
- Line Controls to meet your requirements

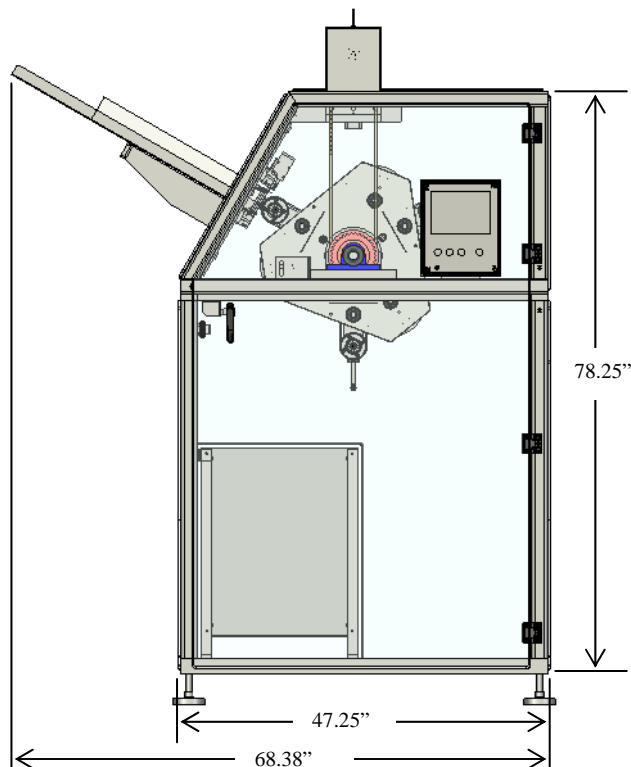
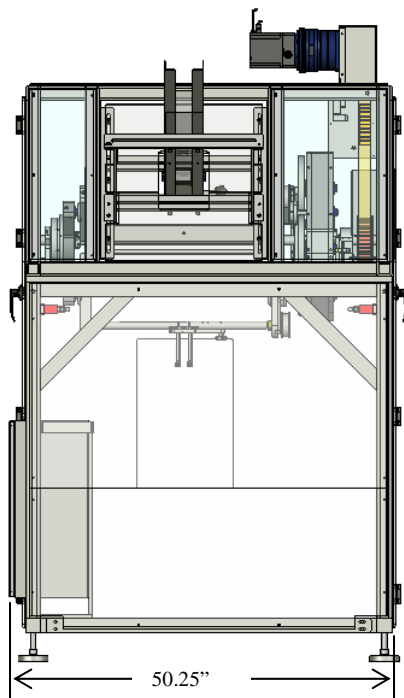

### Products

Coupons – Credit Cards – Back Cards – Phone Cards – Labels Trays – Lids – Bowls – Tubs – Clamshell Trays – Paper – Plastic Premiums – Envelopes – Pouches – Hang Tags – Inserts – CD's - Pizza Circles – Warranty Cards – Promotional Literature – Pads – Glass - **Many, many more**



**GRAPHIC PACKAGING**  
INTERNATIONAL, INC.  
MINNESOTA AUTOMATION PRODUCTS

975 3<sup>rd</sup> Street SW • PO Box 190 • Crosby, MN 56441  
1.888.800.6861 • 218.546.2222 • Fax 218.546.2252  
[www.minnesotaautomation.com](http://www.minnesotaautomation.com) • E-mail: [ma@graphicpkg.com](mailto:ma@graphicpkg.com)