

SERVO RECIPROCATING PLACER

Random Placement
Servo Controlled

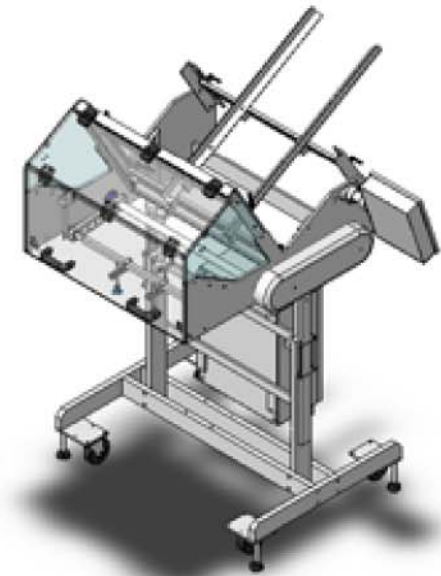

Flexible

Versatile

Dependable



GRAPHIC PACKAGING
INTERNATIONAL, INC.
MINNESOTA AUTOMATION PRODUCTS

This is the next generation of Minnesota Automation Products from Graphic Packaging. Extremely high flexibility is a key feature and this machine is able to handle a huge size range of products. Size changes are quick, easy, and tool free.

Being able to manipulate the speeds of the pivot arm during each cycle allows for a slow pick speed and an accelerated placement speed enabling automation with products that were once limited. Adjustments are at your fingertips with our user-friendly operator interface. A product changeover can be as easy as touching a button.

Everyday you make every effort to gain extra performance in your production lines. Minnesota Automation Products from Graphic Packaging are quality products with unmatched customer support.

Key Features

- Flexibility
Single lane or multiple lanes – Products from coupons to multiple depth trays
- Touch Screen Operator Interface
Allows on demand adjustments for better line efficiency
- Speeds
Run difficult products, at speeds up to 90 cycles per lane per minute
- Changeovers
Quick changeovers; electronically adjust pick depth and placement height
- Maintenance
With fewer moving parts, maintenance is minimized
- Power / Air Requirements 120VAC and 80 PSI

Options

- Construction Grade
Grade #1 Standard Finish – Normal applications where machine is not subject to wash down.
Grade #2 Standard Stainless Finish – Applications where machine is subject to occasional wash down.
Grade #3 Wash Down Finish – Designed for applications where machine is subject to high pressure, high temperature, and caustic wash down.
- Machine Controls
Stand alone machine or integrate with your existing system
- Product Tracking
Pitch application or non-pitch application
- Speeds
Run difficult product at higher speeds
- Changeovers
Quick-change magazines; a lean manufacturing tool to optimize production time
- Height Adjustments
Rapid height adjustment stand available
- Casters
Industrial casters for machine mobility

Products

Coupons – Credit Cards – Back Cards – Phone Cards – Labels - Trays – Lids – Bowls – Tubs – Clamshell Trays – Paper – Plastic Premiums – Envelopes – Pouches – Hang Tags – Inserts – CD's - Pizza Circles – Warranty Cards – Promotional Literature – Pads – Glass - **Many, many more**

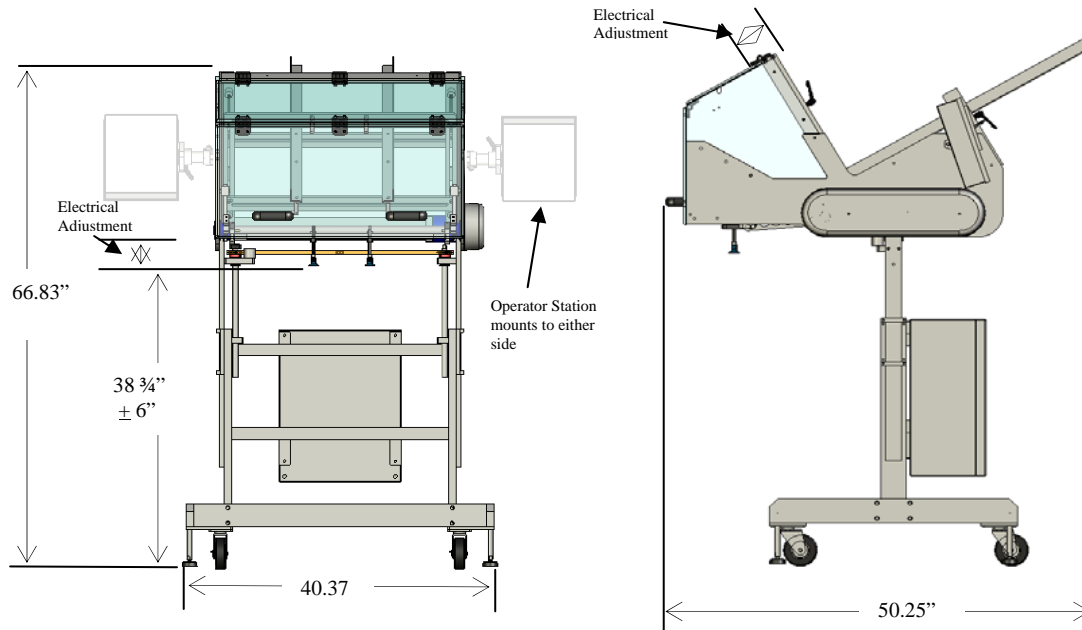

Maximum Product Sizes for Arm Size

Arm Size	Prod Height	Width 12" Model	Width 24" Model	Width 36" Model	Width 48" Model
9" Arm	15"	14 ½"	26 ½"	38 ½"	50 ½"
12" Arm	21 ½"	14 ½"	26 ½"	38 ½"	50 ½"
15" Arm	27 ¾"	14 ½"	26 ½"	38 ½"	50 ½"



GRAPHIC PACKAGING
INTERNATIONAL, INC.
MINNESOTA AUTOMATION PRODUCTS

975 3rd Street SW • PO Box 190 • Crosby, MN 56441
1.888.800.6861 • 218.546.2222 • Fax 218.546.2252
www.minnesotaautomation.com • E-mail: ma@graphicpkg.com